

# Gr 11 & 12 Physical Sciences 2 in 1



## 2009 UPDATE



Supplement 4 ISBN: 978-1-920053-89-5

### Note to grade 12 learner:

In order to keep up to date with the changes in the departmental guidelines, we have constructed this booklet to accompany our study-aid:

### Gr 11 & 12 Physical Sciences 2 in 1

The booklet excludes certain questions which were previously appropriate, but now no longer are, and offers questions on the areas to which the focus has now shifted.

## EXCLUDE (OR REGARD AS OPTIONAL):

### MODULE 1: WAVES, SOUND & LIGHT

- Pg 1.3 ▶ Question 2 - shock waves, interference of soundwaves with jet planes  
▶ Question 1 - 3 - Wave nature of matter (De Broglie)

- Pg 1.5 ▶ Question 8 (Gr 12 Test 1) - De Broglie wavelength

### MODULE 2: MECHANICS

- Pg. 1.7 ▶ Question 6 & 7 - projectile motion in 2-dimensions

- Pg 1.8 ▶ Question 5 - 7 - momentum in 2-dimensions

- Pg 1.11 ▶ Question 7 & 8 (Gr 12 test 2)

### MODULE 3: ELECTRICITY AND MAGNETISM

- Pg. 1.12 ▶ Question 4 - electrodynamics - inductance

- Pg 1.13 ▶ Question 5 & 6 - electromagnetism

- Pg 1.15 ▶ Question 1 - 4 - electronics  
▶ Question 7 - Wheatstone bridge

- Pg. 1.16 ▶ Question 10 - Wheatstone bridge

- Pg. 1.17 ▶ Question 7 - inductance

### MODULE 4: MATTER AND MATERIALS

- Pg. 1.21 ▶ Question 1 - 5 - mechanical properties of matter

- Pg. 1.23 ▶ Question 1 - 5 - organic macromolecules  
▶ Question 1 - 4 - biological macromolecules

- Pg. 1.25 ▶ Question 4 (Gr 12 Test 4)

- Pg. 1.26 ▶ Question 7 & 8 (Gr 12 Test 4)

### MODULE 6: CHEMICAL SYSTEMS

- Pg. 1.37 ▶ Question 3 & 5 - chemical industries

- Pg. 1.39 ▶ Question 4.2 & 7 (Gr 12 Test 6)

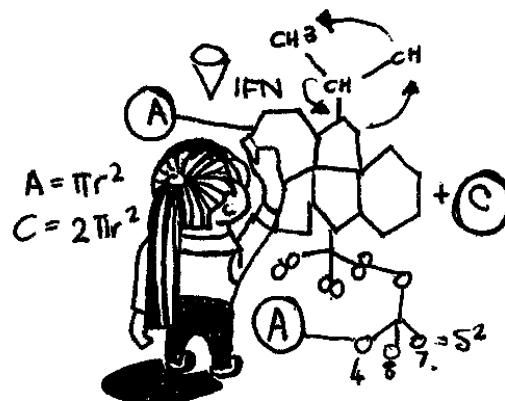

## ADDITIONAL QUESTIONS (NEW CONTENT):

### MODULE 1: WAVES SOUND & LIGHT

#### Question 1 (solution on page 16)

Huygens' principle is used to explain the wave phenomena, interference and diffraction.

- 1.1 State Huygens' principle.
- 1.2 Use Huygens' principle to explain the diffraction of water waves in a ripple tank as they pass through a narrow opening in a barrier.
- 1.3 A single slit of unknown width is illuminated with red light of wavelength 650 nm. Calculate the width of the slit for which the first dark band will appear at  $15^\circ$ .

### MODULE 2: MECHANICS

#### Question 1 (solution on page 16)

A hot-air balloon ride is a favourite item at a holiday resort. The velocity-time graph below represents the motion of the balloon starting from the ground with an initial speed of  $5 \text{ m.s}^{-1}$  during one of the rides. The balloon moves vertically upwards for some time and then it starts moving downwards. Take upwards as positive.

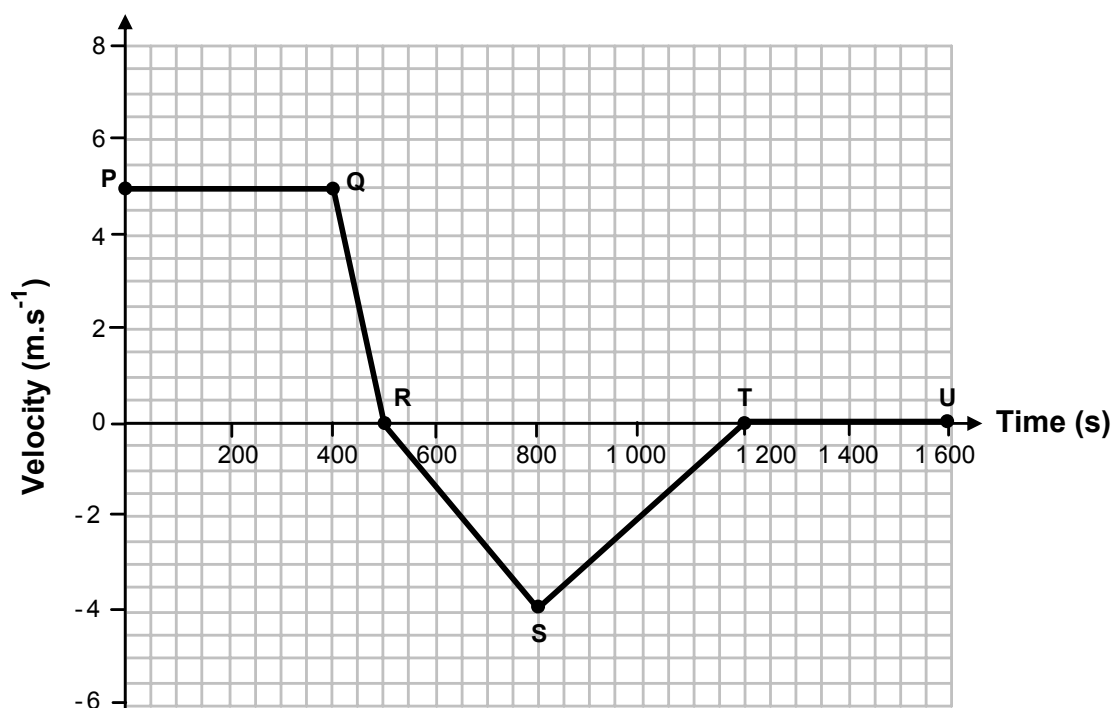

- 1.1 Use the graph to find the maximum height reached by the balloon.
- 1.2 Calculate the average speed during the upward journey.
- 1.3 Briefly describe, in terms of velocity, the motion of the balloon during the interval RS.
- 1.4 Calculate the magnitude of the acceleration of the balloon during the interval QR.
- 1.5 Without calculation, state the speed of the balloon at point T.
- 1.6 Calculate the height of the balloon above the ground, when it is at point T.
- 1.7 Draw a sketch graph of displacement versus time for the motion of the balloon from R to U ( $t = 500 \text{ s}$  to  $t = 1600 \text{ s}$ ). No numerical values need to be indicated.

**Question 2** (solution on page 17)

A steel ball is dropped from rest at point A above a window. The ball takes 0,25 s to travel from B to C, which is a window of length (height) 1,5 m. Ignore the effects of air resistance.

- 2.1 Define, in words, the term **displacement**.
- 2.2 Show, by calculation, that the velocity of the ball at B is equal to  $4,75 \text{ m}\cdot\text{s}^{-1}$ .
- 2.3 Use relevant equations of motion to calculate the height ( $s_{AB}$ ) above the top of the window, from where the steel ball was dropped.

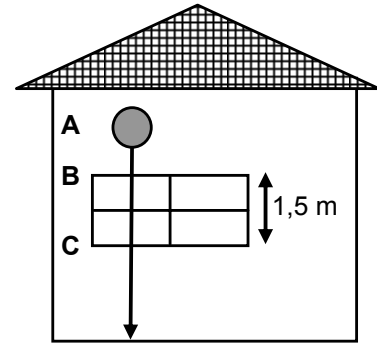

**Question 3** (solution on page 17)

Lihle and her car have a combined mass of 1 300 kg and the car is travelling at  $24 \text{ m}\cdot\text{s}^{-1}$ . Lihle sees an obstruction in the road ahead and brakes sharply to produce a constant deceleration (negative acceleration) of  $6 \text{ m}\cdot\text{s}^{-2}$ .

- 3.1 Calculate the magnitude of the force exerted by the brakes on the wheels of the car during braking.
- 3.2 Calculate the work done by the brakes during braking if the car comes to a stop before hitting the obstruction.
- 3.3 Make use of **impulse** ( $F\Delta t = m\Delta v$ ) and your answer to QUESTION 3.1 to calculate the time taken to come to a stop.

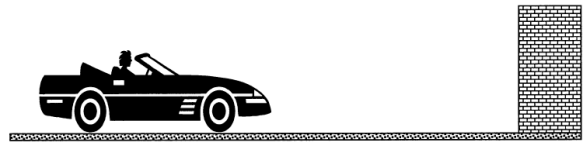

During braking, Lihle experiences continuous forward motion.

- 3.4 Name the law of physics applicable to this situation.

**Question 4** (solution on page 18)

The roof of a tall building is 25 m above the ground. A rigid ball of mass 0,3 kg falls freely when dropped from the roof. It strikes the concrete floor on the ground with velocity  $v_1$ . It bounces to a maximum vertical height of 6 m. The ball was in contact with the floor for 0,9 s. Ignore the effects of friction.

- 4.1 Calculate the velocity  $v_1$  when the ball first hits the floor.
- 4.2 Calculate the impulse of the ball as a result of the collision.
- 4.3 Calculate the magnitude of the net force exerted on the ball.
- 4.4 Using the ground as zero reference, draw a sketch graph of position (displacement) versus time for the motion of the ball from its original height until it reaches its second maximum height. Indicate the relevant position values on the y-axis.

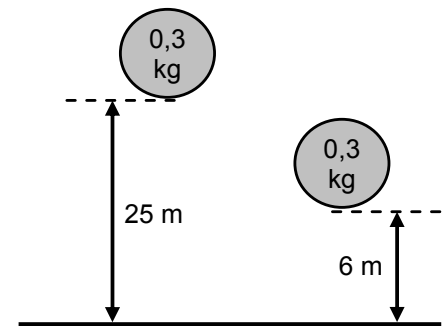

- 4.5 The rigid ball is now replaced with a softer ball of the same mass and volume as the rigid ball. It is then dropped from the same height onto the concrete floor. Will the height reached by this ball be the **same as**, **greater than** or **less than** that reached by the first ball? Use principles of physics to explain your answer.

**Question 5** (solution on page 19)

Percy, of mass 75 kg, rides a quad bike (motorcycle with 4 wheels) with a mass of 100 kg, at a speed of  $20 \text{ m.s}^{-1}$ . As he approaches a red traffic light on a wet and slippery road, he suddenly applies the brakes. The wheels of the quad bike lock and it skids (slides) in a straight line. The force of friction due to the road causes the bike to change its velocity from  $20 \text{ m.s}^{-1}$  to  $0 \text{ m.s}^{-1}$  in 8 s.

- 5.1 State, in words, the **Principle of Conservation of Momentum**.
- 5.2 Percy states that the reason why he kept moving forward was because of the conservation of momentum. Is his statement TRUE or FALSE?
- 5.3 Determine the change in momentum of Percy and the bike, from the moment the brakes lock until the bike comes to a stop.
- 5.4 Calculate the magnitude of the average frictional force exerted by the road on the wheels.
- 5.5 Calculate the work done by the frictional force in bringing the quad bike to rest.

**MODULE 3: ELECTRICITY AND MAGNETISM**

**Question 1** (solution on page 19)

A light bulb that is marked 100 W is used in your room as a light source. A potential difference of 220 V across the bulb ensures a work rate of 100 W.

- 1.1 Calculate the amount of charge that flows through this light bulb.
- 1.2 What is meant by "potential difference"?
- 1.3 Determine the resistance of the filament in the light bulb.
- 1.4 What do you understand by the term "electrical current"?
- 1.5 Calculate the magnitude of the electrical current that flows through the light bulb.
- 1.6 What will happen to the power of the light bulb if it is coupled to a 110 V circuit? Explain.



**Question 2** (solution on page 20)

Two light bulbs, X and Y, are connected in series with a 6 V battery. When the switch of the circuit is closed, X is brighter than Y.

- 2.1 Draw the circuit.
  - 2.2 Explain why the one bulb burns brighter than the other.
- Use the same components and connect the two bulbs in parallel with each other.
- 2.3 Draw the circuit.
  - 2.4 What will happen now regarding the brightness of the two light bulbs? Explain.

**Question 3** (solution on page 21)

Consider the graph below:

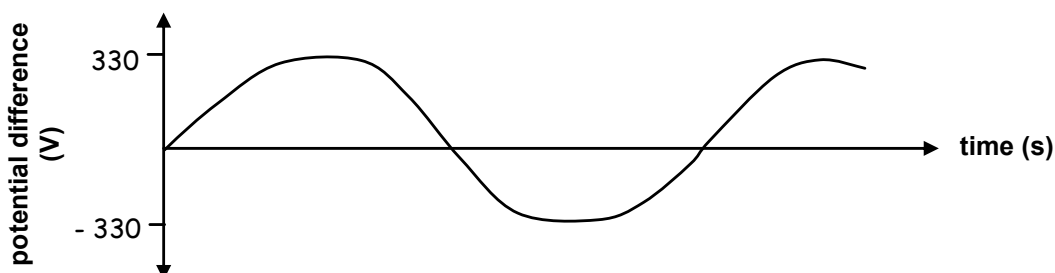

- 3.1 What is represented by this graph?
- 3.2 What device will produce this type of graph?
- 3.3 If a current of 15 A (rms) is produced, determine the rate at which this device will transfer energy.
- 3.4 Determine the value of the maximum possible current.

**Question 4** (solution on page 21)

Each plate of a parallel plate capacitor has an area of  $40 \text{ cm}^2$ . The plates are 1 cm apart. The capacitor is connected to a 12 V DC supply.

- 4.1 Calculate the magnitude of the charge on each plate.
- 4.2 By which factor will the charge calculated in QUESTION 4.1 change if the area of each parallel plate is changed to  $20 \text{ cm}^2$ ? Explain your answer in terms of physics principles and the charge stored in the capacitor. (NO calculations needed).
- 4.3 What is the net charge on the capacitor?
- 4.4 Capacitors are used in camera flashes. Give a reason for this use.

**Question 5** (solution on page 22)

- 5.1 In the circuit below the AC source delivers alternating voltages at audio frequency to the speaker.

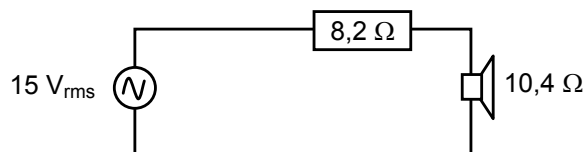

- 5.1.1 What is the peak voltage that the source can deliver?
- 5.1.2 Calculate the average power delivered to the speaker.
- 5.2 Alternating current is generated at power stations.  
Name **two** advantages of AC transmission over long distances.

**Question 6** (solution on page 22)

Lindi investigates the relationship between the current and the energy transferred by a resistor X, immersed in water in an insulated calorimeter. She applies constant currents of 1 A, 2 A, 3 A and 4 A, each for a period of 5 minutes. She uses a thermometer to measure the rise in temperature corresponding to each of the applied currents. The mass of the water is kept constant throughout the experiment. The diagram below shows the set-up of the apparatus used.

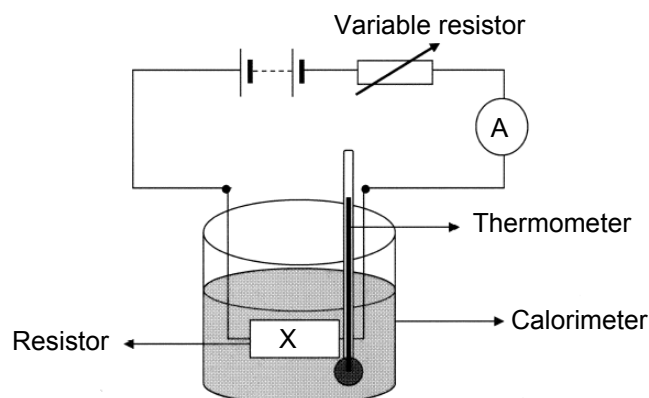

The energy,  $W$ , transferred by resistor  $X$ , was calculated in each experiment assuming 100 % efficiency. The values are presented in a table.

Current ( $I$ ) in A	Current <sup>2</sup> ( $I^2$ ) in A <sup>2</sup>	Energy ( $W$ ) transferred by resistor $X$ in joules
1	1	600
2	4	2 400
3	9	5 400
4	16	9 600

- 6.1 Use a suitable scale to draw a graph with energy transferred on the vertical (dependent) axis and  $I^2$  on the horizontal (independent) axis. Plot the points and sketch a straight-line graph. Label your graph clearly.
- 6.2 Describe in words the relationship between  $I^2$  and the energy transferred by the resistor, as reflected by the graph.
- 6.3 Calculate the resistance of the resistor Lindi used in her investigation.

**Question 7** (solution on page 23)

Thembi wants to listen to her radio which is rated 6 V, 3 W. The only available battery is a 24 V battery. She decides to use an appropriate resistor to get the correct voltage for her radio.

- 7.1 Calculate the maximum current which the radio draws from the battery when operating at its rated voltage.
- 7.2 Draw a circuit diagram to show how Thembi should connect the resistor to the radio and the battery.
- 7.3 If the battery has an internal resistance of  $2 \Omega$ , calculate the resistance of the resistor which Thembi has to use.

**Question 8** (solution on page 23)

The element of an electric kettle is rated at 1 320 W when operating on a 220 V supply. Calculate the total charge passing through the element in 10 minutes of operation.

**Question 9** (solution on page 23)

A person uses a multiplug and connects a 200 V; 1 500 W heater and a 200 V; 1 000 W hair dryer to the same electric outlet. This outlet is in a section of the electric circuit in the house which contains a 10 A trip switch. Determine, by means of the necessary calculations, whether these two appliances can be used together from the same electric outlet.

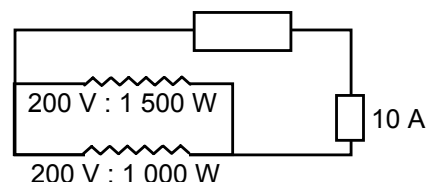

## MODULE 4: MATTER AND MATERIALS

### Question 1 (solution on page 24)

The flow diagram below shows the mutual interaction between alcohols, alkenes and halo-alkanes. The letters A, B, C, D, E and F represent addition, substitution or elimination reactions.

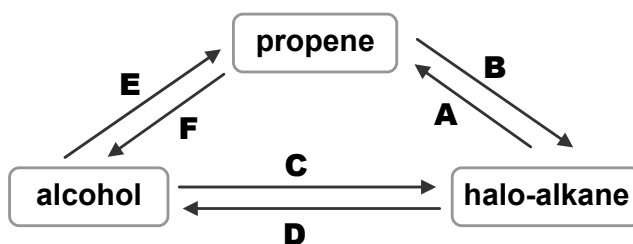

- 1.1 What type of reaction is represented by F? Choose from ADDITION, SUBSTITUTION or ELIMINATION.
- 1.2 Use structural formulae and write a balanced equation for reaction F to show the formation of the main product.
- 1.3 Reaction E is sometimes known as dehydration. Write down the FORMULA of the substance that is eliminated during dehydration.
- 1.4 Letter C represents the reaction of alcohol with NaBr(aq) in the presence of sulphuric acid as a catalyst.
  - 1.4.1 Write down the structural formula for the organic product of this reaction.
  - 1.4.2 What type of reaction is represented by C? Choose from ADDITION, SUBSTITUTION or ELIMINATION.
- 1.5 The haloalkane is converted to alcohol by reaction D, or to propene by reaction A.
  - 1.5.1 What type of reaction is represented by A? Choose from ADDITION, SUBSTITUTION or ELIMINATION.
  - 1.5.2 What type of reaction is represented by D? Choose from ADDITION, SUBSTITUTION or ELIMINATION.
  - 1.5.3 Under what conditions will reaction A take place?

### Question 2 (solution on page 24)

A scientist finds a bottle containing an organic liquid in the laboratory. The label on the bottle has been partially washed off. From what is visible on the label, she can make out that the liquid is either cyclohexane or cyclohexene.

She carries out an experiment to identify the liquid and determines that it is unsaturated.

- 2.1 Identify the compound in the bottle.
- 2.2 Design the experiment that the scientist probably carried out to reach the above conclusion. Use the following steps as guidelines in your design:
  - 2.2.1 Apparatus required
  - 2.2.2 Chemicals needed
  - 2.2.3 Method that describes the steps that must be followed.
  - 2.2.4 What will be observed and how the results can be used to make a conclusion.
- 2.3 Draw the structural formula of cyclohexane.

### Question 3 (solution on page 25)

There are two structural isomers for the organic compound with molecular formula  $C_2H_4O_2$ .

- 3.1 Define the term **structural isomer**.
- 3.2 Write down the structural formula of these two isomers and next to each its IUPAC name.
- 3.3 State with reason which ONE of these isomers:
  - 3.3.1 has the higher boiling point
  - 3.3.2 has the higher vapour pressure
- 3.4 Will the vapour pressure of carboxylic acids increase or decrease if the number of carbon atoms in the chain increases? Give a reason for your answer.

### Question 4 (solution on page 25)

Rubber is a naturally occurring compound. The diene, 2-methyl-1,3-butadiene, is one of the repeating units found in rubber.

Over 20 million families depend on rubber cultivation for their livelihood. Tens of thousands of hectares of tropical forests have been cleared to make way for rubber plantations.

Chemists have been able to combine other dienes to obtain synthetic rubbers. Some rubber products include latex products such as hand gloves, raincoats and other products used in the battle against HIV/AIDS.

The world's largest use of rubber is in tyres, and most tyres contain both natural rubber, which withstands heat better, and one or more kinds of synthetic rubber.

- 4.1 Is 2-methyl-1,3-butadiene an example of a saturated or an unsaturated hydrocarbon? Give a reason for your answer.
- 4.2 Write down the structural formula of 2-methyl-1,3-butadiene.
- 4.3 With regard to the environment, name TWO disadvantages of rubber and the production of rubber.
- 4.4 With regard to human life, name TWO benefits of rubber and the production of rubber.

### Question 5 (solution on page 25)

Most organic compounds can undergo substitution, addition or elimination reactions to produce a variety of organic compounds. Some incomplete organic reactions are represented below.

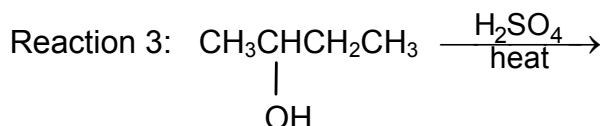
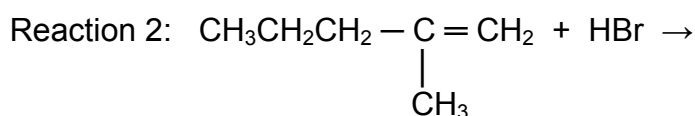
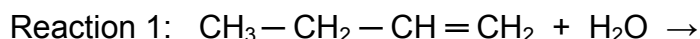

- 5.1 Name the type of reaction represented by reaction 3.
- 5.2 Both reactions 1 and 2 are examples of addition reactions. Name the type of addition that is represented by each reaction.
- 5.3 Write down the structural formula and IUPAC name of the major product formed in reaction 1.
- 5.4 Reaction 1 only takes place in the presence of a catalyst. Write down the formula of the catalyst used in reaction 1.
- 5.5 Write down the structural formula and IUPAC name of the major product formed in reaction 2.
- 5.6 To which homologous series does the organic product formed in reaction 3 belong?

**Question 6** (solution on page 26)

Consider the following compounds:

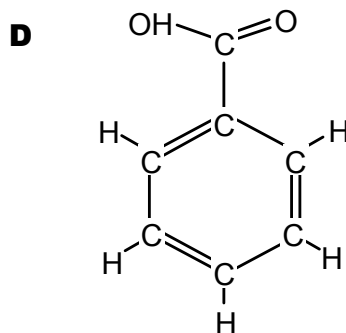
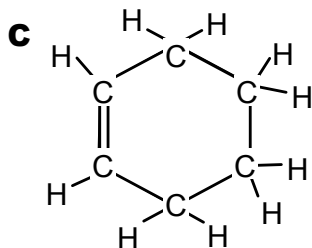
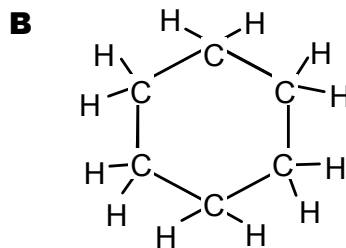
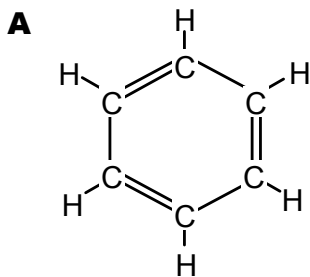

- 6.1 Which of the above compounds can be considered unsaturated?
- 6.2 To which homologous group do each of these compounds belong?
- 6.3 Write down the IUPAC name for each compound.
- 6.4 Which one of these compounds will undergo a substitution reaction easier than the rest?
- 6.5 Which one of the compounds can take part in the process of esterification?

**Question 7** (solution on page 26)

Consider each of the following organic compounds:

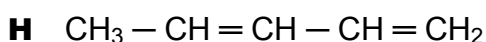
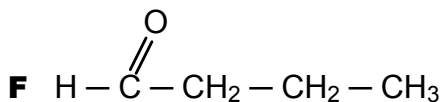
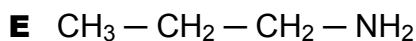
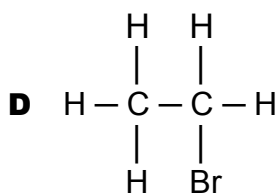
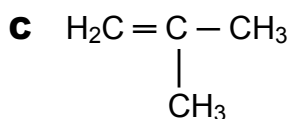
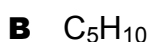
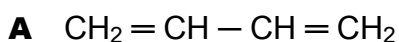

- 7.1 Provide the name of the homologous series to which each of the compounds belong.
- 7.2 Provide the IUPAC name for each compound.
- 7.3 Write down the structural formula and name of an isomer of compound C.
- 7.4 Write down an equation for the reaction between B and hydrogen. Also give the name of this type of reaction.
- 7.5 Write down an equation for the halogenation of C with chlorine. Also give the name of the product formed.
- 7.6 Write down an equation for the reaction of D with potassium hydroxide. Give the name of the organic product that forms, as well as the name of this type of reaction.

**Question 8** (solution on page 27)

- 8.1 Liquid oils are converted to fats such as margarine during a chemical process. NAME the type of reaction that occurs during this process.
- 8.2 A gaseous hydrocarbon with 3 carbon atoms per molecule is decolourised by bromine water.
- 8.2.1 Is this hydrocarbon saturated or unsaturated?
- 8.2.2 Write down the IUPAC name of the hydrocarbon.
- 8.2.3 Use structural formulae to write down the equation for the reaction of the hydrocarbon with bromine.
- 8.3 Hexane burns in excess oxygen. Write down a balanced equation for this reaction.
- 8.4 Study the flow diagram below and answer the questions that follow.

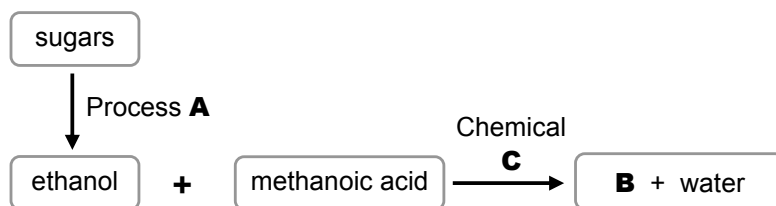

- 8.4.1 Write down the name of process **A** through which ethanol is produced.
- 8.4.2 Write down the structural formula and IUPAC name for compound **B**.
- 8.4.3 What is the function of chemical **C** in the reaction?

**Question 9** (solution on page 28)

- 9.1 Consider the following organic compound:



For this compound write down the following:

- 9.1.1 IUPAC name
- 9.1.2 Functional group
- 9.2 Methane is burnt in excess oxygen. Write down a balanced equation for the reaction.
- 9.3 Write down the structural formula for but-1-ene (1-butene).
- 9.4 Bromine water is added to a solution of but-2-ene (2-butene).
- 9.4.1 Write down the IUPAC name for the product formed in this reaction.
- 9.4.2 What type of reaction will take place?  
Choose from: OXIDATION, HYDROGENATION or ADDITION.

**Question 10** (solution on page 28)

Alkenes such as ethene, propene and others are used as ingredients in the production of plastic. Consider the following two reactions and answer the questions that follow:

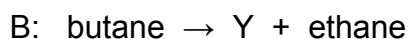

- 10.1 Use structural formulae and complete the reaction equations.
- 10.2 What is the name of the type of reaction that takes place in A?
- 10.3 What conditions are necessary for reaction B to take place?
- 10.4 Provide the name of the type of reaction that takes place in B.
- 10.5 Explain what happens during such a reaction as named in 10.4.
- 10.6 Where in the industry are these types of reactions used on a large scale?

**Question 11** (solution on page 28)

Ethane is cracked at a temperature of approximately 800°C and in the presence of a catalyst.

- 11.1 Provide the name of the catalyst that is used in this reaction.
- 11.2 Write down a balanced equation of the cracking process.
- 11.3 What general name is given to this type of reaction?
- 11.4 Why is a catalyst still needed in the above reaction?

**Question 12** (solution on page 29)

During an elimination reaction pentane can be broken up into an alkene (made up of 3 carbon atoms) and an alkane.

- 12.1 Write down a balanced reaction equation for this reaction. (Use structural formulae.)
- 12.2 Rewrite the above equation using molecular formulae.
- 12.3 Provide the IUPAC-names of all of the molecules involved.
- 12.4 What factor initiates this reaction?
- 12.5 What name is given to this type of elimination reaction?

**MODULE 5: CHEMICAL CHANGE****Question 1** (solution on page 29)

Learners investigate one of the factors that influence the rate of a chemical reaction. The arrangement for the experiment is given below.

Test tube	Contents of test tube
A	1 g potassium chlorate (KClO <sub>3</sub> ) + 5 g manganese (IV) oxide (MnO <sub>2</sub> )
B	1 g potassium chlorate (KClO <sub>3</sub> )
C	5 g manganese (IV) oxide (MnO <sub>2</sub> )

The test tubes were set up in a sand bath and then evenly heated. The oxygen produced was measured at 60 second intervals. No reading was obtained for test tube C. The graph shows the results obtained during the experiment.

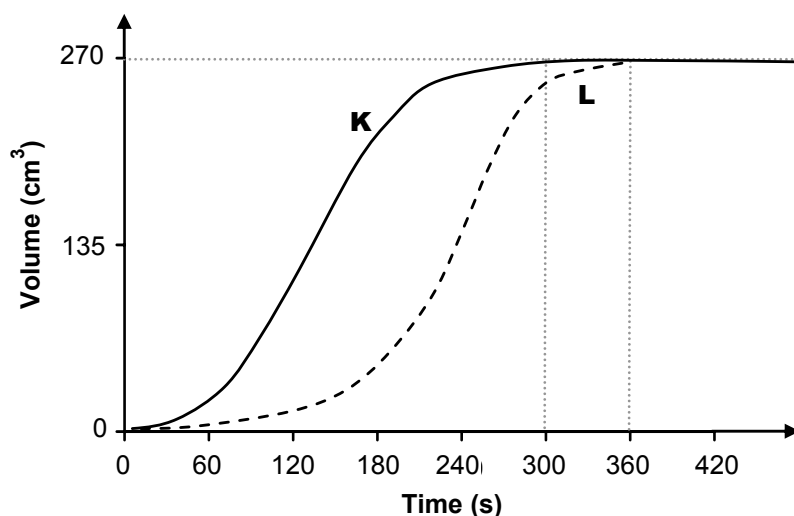

The equation for the production of oxygen using potassium chlorate:



- 1.1 Which factor was being investigated?
- 1.2 Which graph line, K or L, was obtained for the reaction in test tube B?
- 1.3 Give a reason for your answer to QUESTION 1.2.

If the mass of  $\text{MnO}_2$  in test tube A was increased, how will each of the following change? Choose from INCREASES, DECREASES or NO CHANGE.

- 1.4 The volume of oxygen produced.
- 1.5 The rate of the reaction.

**Question 2** (solution on page 29)

- 2.1 Consider the following reaction which reaches equilibrium in a closed container.

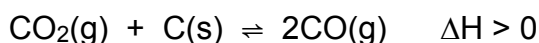

How will the amount of CO change when the following takes place?

Choose from: INCREASES, DECREASES or NO CHANGE.

- 2.1.1 Temperature is decreased
- 2.1.2 Volume of the container is increased at constant temperature

- 2.2 The acid-base equilibrium for phenolphthalein ( $\text{C}_{20}\text{H}_{12}\text{O}_4(\text{aq})$ ) in solution is represented by the equation below.

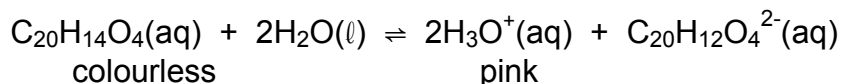

Explain, using Le Chatelier's principle, why phenolphthalein is colourless when a solution of hydrochloric acid is added to it.

- 2.3 At a certain temperature solutions of  $\text{N}_2$ ,  $\text{H}_2$  and  $\text{NH}_3$ , each with a concentration of  $0,50 \text{ mol}\cdot\text{dm}^{-3}$ , are placed in a sealed container. At equilibrium the concentration of  $\text{N}_2$  is  $0,40 \text{ mol}\cdot\text{dm}^{-3}$ . The equation for the reaction at equilibrium is:

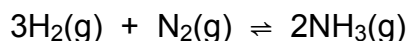

Calculate the equilibrium constant for the reaction at this temperature.

**Question 3** (solution on page 30)

Nitrogen and hydrogen react in a closed container until the following equilibrium is reached:

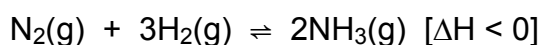

- 3.1 Write down Le Chatelier's principle in your own words.
- 3.2 Use this principle to explain how each of the following changes will influence the above equilibrium:
  - 3.2.1 the volume of the container is increased
  - 3.2.2 the temperature of the system is decreased
  - 3.2.3 the pressure on the system is increased
  - 3.2.4 more  $\text{H}_2$  is added
  - 3.2.5 ammonia is removed from the system
  - 3.2.6 a catalyst is added to the reaction solution
  - 3.2.7 the temperature of the system is increased



**Question 4** (solution on page 31)

Consider the following graph of reaction rate against time for the reaction:

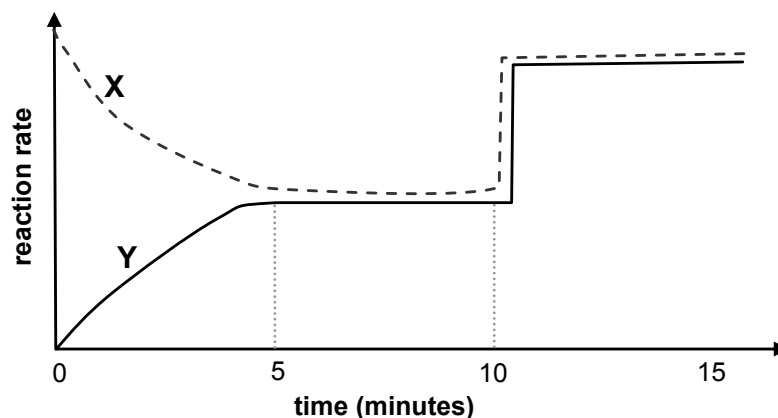
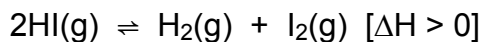

- 4.1 Which reaction (forward or reverse) is represented by graph X and Y, respectively? Explain.
- 4.2 After how many minutes is equilibrium reached for the first time? Motivate your answer.
- 4.3 What change (pressure, temperature or concentration) to the equilibrium system took place at a time of 10 minutes? Explain.
- 4.4 What changes can be made to the equilibrium system to bring about the largest possible yield of HI(g)? Explain.

**Question 5** (solution on page 31)

An amount of SO<sub>3</sub> is sealed in a container at 400°C and the following reversible reaction takes place:

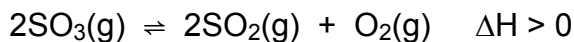

The accompanying graph shows how the reaction rate, measured from the start of the reaction, changed with time.

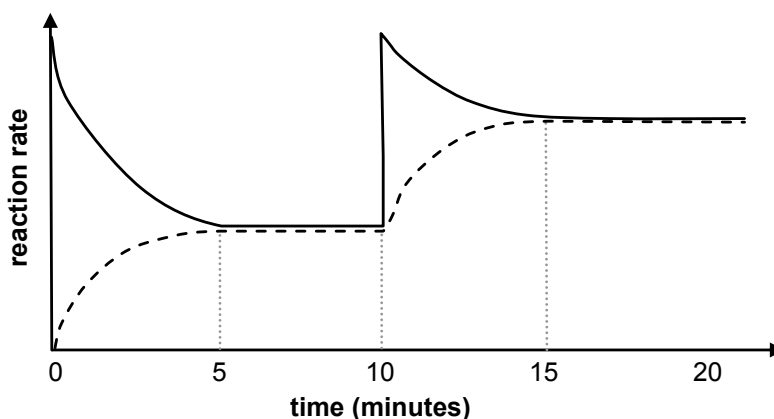

- 5.1 State, giving a reason, whether the forward reaction above is homogenous or heterogeneous.
- 5.2 Write down the equation for the reaction that is indicated by the solid line.
- 5.3 How long does it take for the reaction to first reach equilibrium from the start?
- 5.4 State what possibly could have happened to the system at the tenth minute.
- 5.5 Why is the horizontal part of the graph between the fifteenth and twentieth minute higher than the horizontal part between the fifth and tenth minute?
- 5.6 How will an increase in pressure affect the amount of SO<sub>2</sub>(g) present in the container at equilibrium?

### Question 6 (solution on page 31)

6.1 Sharon conducts an experiment to investigate the various factors that influence the rate of chemical reactions.

She places a sample of calcium carbonate in a beaker. The beaker is placed on a sensitive balance and an **excess** of hydrochloric acid (HCl) is added.

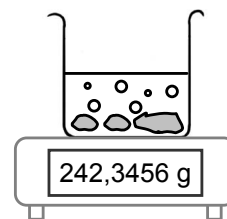

Sharon repeats the experiment a number of times under different conditions, always with the **same volume of HCl in excess**.

The following table summarises the different experimental conditions of four of her experiments (numbered 1 - 4).

Experiment number	Mass of CaCO <sub>3</sub> (g)	Concentration of HCl (mol.dm <sup>-3</sup> )	Temperature of HCl (°C)	State of CaCO <sub>3</sub> (s)
1	10	2	25	granules
2	10	2	15	granules
3	20	2	25	granules
4	10	2	25	powder

During each experiment the mass of the beaker and its contents is recorded every minute.

The graphs below indicate the changes in mass of the beaker and its contents during the reaction, as a function of time, for the four experiments:

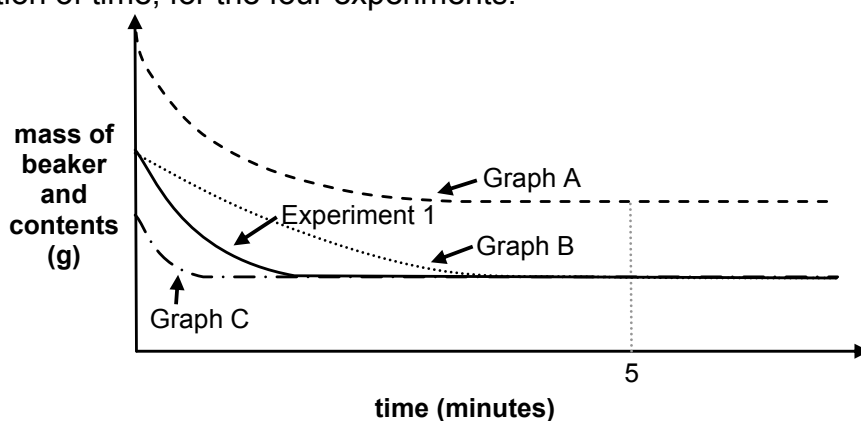

6.1.1 Give a reason for the decrease in mass as each reaction progresses.

6.1.2 Why are all the graphs straight lines after five minutes?

6.1.3 Which ONE of the graphs A, B or C, represents the results of:

- Experiment 2
- Experiment 3
- Experiment 4

6.2 Seven (7,0) moles of nitrogen gas (N<sub>2</sub>) and 2,0 moles of oxygen gas (O<sub>2</sub>) are placed in an empty container of volume 2 dm<sup>2</sup>.

The container is sealed and the following equilibrium is established: N<sub>2</sub>(g) + O<sub>2</sub>(g) ⇌ 2NO(g)

The K<sub>c</sub> value for this reaction at 25°C is 4,8 × 10<sup>-31</sup>.

6.2.1 What information does this value of K<sub>c</sub> indicate with regards to the amount of NO(g) in the equilibrium mixture at 25°C?

*The container is heated and the system reaches a new equilibrium at 2 500°C. At this temperature it is found that there are 0,4 moles of NO(g) present.*

6.2.2 Determine the K<sub>c</sub> value at this temperature.

6.2.3 Making use of Le Chatelier's principle, explain how we know that the forward reaction is endothermic.

## MODULE 6: CHEMICAL SYSTEMS

### Question 1 (solution on page 32)

About one third of the protein consumed by humans comes from fertilisers. The flow diagram below shows three industrial processes, A, B and C, that result in the production of fertilisers.

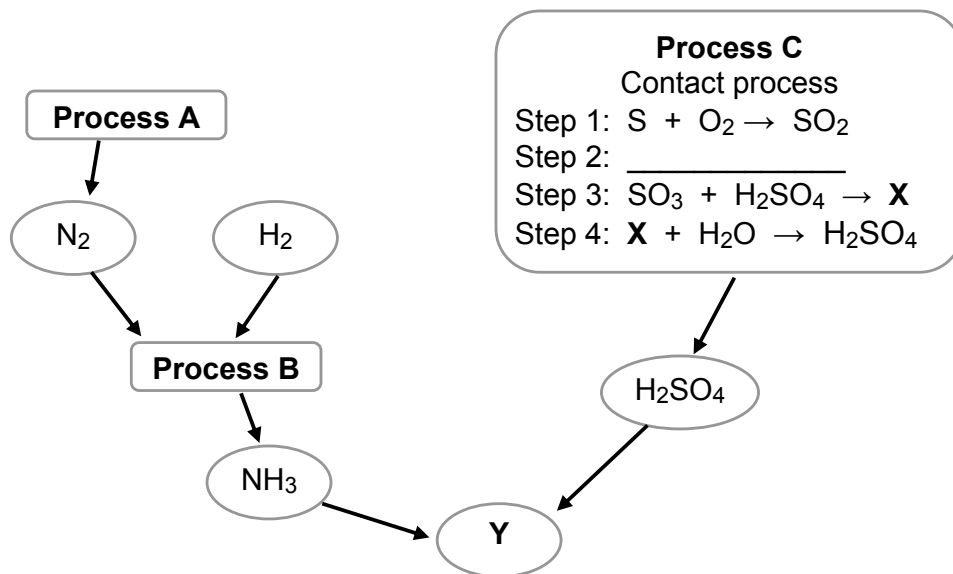

- 1.1 Write down the name of the Process A.
- 1.2 Write down the balanced equation for the reaction which takes place in process B.
- 1.3 Write down the balanced equation for step 2 of Process C.
- 1.4 Write down the FORMULA and the NAME of product X in step 3 of Process C.
- 1.5 Write the FORMULA and the NAME of the fertiliser represented by Y.
- 1.6 Fertiliser prices have increased by more than 200 percent since 2007. This rise is fuelled by new demand.
  - 1.6.1 Give TWO reasons why there is a continuous demand for fertilisers.
  - 1.6.2 Give TWO reasons why there is an increase in the price of fertilisers.

### Question 2 (solution on page 32)

A simplified flow diagram for the Ostwald process is shown below.

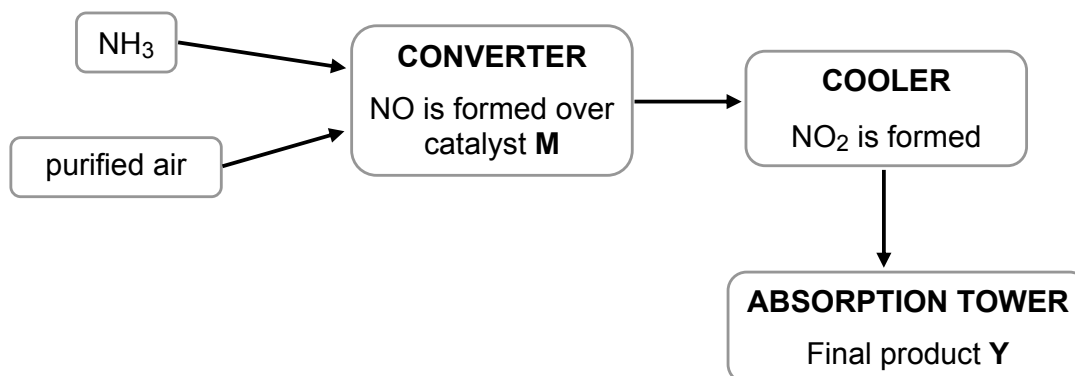

- 2.1 Write down the NAME of the catalyst M that is used in the converter.
- 2.2 Write down a balanced equation for the reaction that produces the gas  $NO$  in the converter.
- 2.3 Write down the NAME of the final product Y.
- 2.4 Pure nitric acid is a colourless liquid. However, it turns yellow when exposed to sunlight. Explain this observation.

# THE ANSWERS

## MODULE 1: WAVES SOUND & LIGHT

### QUESTION 1

- 1.1 Each point on the wavefront acts as a source of spherical secondary waves or wavelets travelling away from source.
- 1.2 Each point on the initial plane wavefront entering the slit acts as a source of secondary wavelets. The wavelets propagate in all directions beyond the slit causing the wave to spread into regions beyond those in line with the slit.

1.3  $\sin\theta = m \frac{\lambda}{a}$

$$\therefore \sin 15^\circ = 1 \times \frac{650 \times 10^{-9}}{a}$$

$$\therefore a = 2,7 \times 10^{-6} \text{ m}$$

**u** or **v<sub>i</sub>** is the initial velocity  
**v** or **v<sub>f</sub>** is the final velocity  
**t** or **Δt** is the time taken  
**s** or **Δx** (horizontal) or **Δy** (vertical) is the displacement  
**g** or **a** is the acceleration due to gravity

## MODULE 2: MECHANICS

### QUESTION 1

1.1 height = surface area under graph

$$= (l \times b) + \left(\frac{1}{2} \cdot bh\right)$$

$$= (5 \times 400) + \left(\frac{1}{2} \times 100 \times 5\right)$$

$$= 2\,000 + 250$$

$$= 2\,250 \text{ m or } 2,25 \text{ km}$$

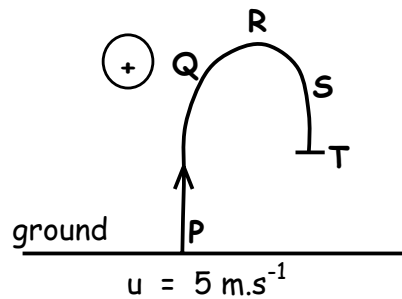

1.2  $s = \left[ \frac{u+v}{2} \right] \cdot t$

$$\left[ \frac{u+v}{2} \right] = \frac{s}{t}$$

$$= \frac{2\,250}{500}$$

$$= 4,5 \text{ m.s}^{-1}$$

$$\left[ \frac{u+v}{2} \right] = \text{ave. speed}$$

$$s = 2\,250 \text{ m}$$

$$t = 500 \text{ s}$$

- 1.3 Point R is the maximum height that the balloon reached. At this point the velocity of the balloon is zero. As the balloon moved down, its velocity increased within 300 s from  $0 \text{ m.s}^{-1}$  to  $4 \text{ m.s}^{-1}$ .

1.4 acceleration = gradient of QR

$$= \frac{-5}{100}$$

$$= -0,05 \text{ m.s}^{-2}$$

OR:

$$v = u + at$$

$$0 = 5 + a(100)$$

$$a = 0,05 \text{ m.s}^{-2}$$

1.5  $0 \text{ m.s}^{-1}$  (no motion)

1.6 height above ground = surface area above time axis - surface area below time axis

$$= 2\,250 \text{ m} - \left[ \left(\frac{1}{2} \times 300 \times 4\right) + \left(\frac{1}{2} \times 400 \times 4\right) \right]$$

$$= 2\,250 - (600 + 800)$$

$$= 850 \text{ m}$$

1.7

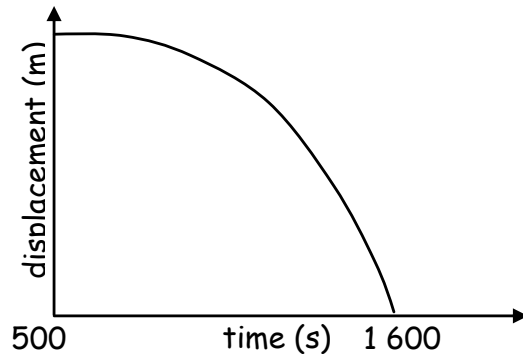

## QUESTION 2

2.1 Displacement is the distance travelled in a certain direction. (Vector quantity)

$$2.2 \quad s = ut + \frac{1}{2}gt^2$$

$$1,5 = u(0,25) + \left(\frac{1}{2} \times 10 \times 0,25^2\right)$$

$$1,5 = u(0,25) + 0,3125$$

$$u = 4,75 \text{ m}\cdot\text{s}^{-1}$$

[if  $g = 9,8 \text{ m}\cdot\text{s}^{-2}$  is used,  $u = 4,77 \text{ m}\cdot\text{s}^{-1}$ ]

$$s = 1,5 \text{ m}$$

$$t = 0,25 \text{ s}$$

$$g = 10 \text{ m}\cdot\text{s}^{-2}$$

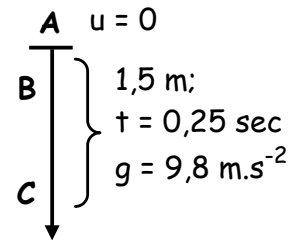

$$2.3 \quad v^2 = u^2 + 2gs$$

$$(4,75)^2 = 0 + 2(10)\cdot s$$

$$22,5625 = 0 + 20\cdot s$$

$$s = 1,13 \text{ m}$$

$$v = 4,75 \text{ m}\cdot\text{s}^{-1}$$

$$u = 0$$

$$g = 10 \text{ m}\cdot\text{s}^{-2}$$

## QUESTION 3

$$3.1 \quad F_{\text{net}} = m\cdot a$$

$$= 1\,300 \times (-6)$$

$$= -7\,800$$

$$m = 1\,300 \text{ kg}$$

$$a = -6 \text{ m}\cdot\text{s}^{-2}$$

$F_{\text{net}} = 7\,800 \text{ N}$  in the opposite direction of motion

3.2 [work done = energy transferred]

$$W = Ek$$

$$= \frac{1}{2}mv^2$$

$$= \frac{1}{2} \times 1\,300 \times 24^2$$

$$= 374\,400 \text{ J}$$

$$= 374,4 \text{ kJ}$$

Can also use:

$$v^2 = u^2 + 2as, \text{ and}$$

$$W = F\cdot s$$

$$3.3 \quad F\Delta t = m\Delta v$$

$$\Delta t = \frac{m\Delta v}{F} = \frac{m(v-u)}{F}$$

$$= \frac{1\,300(0-24)}{-7\,800}$$

$$= 4 \text{ seconds}$$

$$m = 1\,300 \text{ kg}$$

$$v = 0$$

$$u = 24 \text{ m}\cdot\text{s}^{-1}$$

$$F = -7\,800 \text{ N}$$

$u$  or  $v_i$  is the initial velocity

$v$  or  $v_f$  is the final velocity

$t$  or  $\Delta t$  is the time taken

$s$  or  $\Delta x$  (horizontal) or  $\Delta y$  (vertical) is the displacement

$g$  or  $a$  is the acceleration due to gravity

3.4 Newton I (inertia)

## QUESTION 4

4.1  $v_f^2 = v_i^2 + 2a\Delta x$  (or  $v^2 = u^2 + 2gs$ )  
 $v_f^2 = (0)^2 + 2(-9,8)(25)$   
 $v_f = -22,13$  or  $22,13 \text{ m.s}^{-1}$  down

OR  $E_t(\text{top}) = E_t(\text{bottom})$   
 $E_p + E_k = E_p + E_k$   
 $mgh + 0 = 0 + \frac{1}{2}mv_f^2$   
 $(0,3)(9,8)(25) + 0 = 0 + \frac{1}{2}mv_f^2$   
 $v_f = 22,13 \text{ m.s}^{-1}$  downwards

$u$  or  $v_i$  is the initial velocity  
 $v$  or  $v_f$  is the final velocity  
 $t$  or  $\Delta t$  is the time taken  
 $s$  or  $\Delta x$  (horizontal) or  $\Delta y$  (vertical) is the displacement  
 $g$  or  $a$  is the acceleration due to gravity  
 $E_p$  or  $U$  is potential energy  
 $E_k$  or  $K$  is kinetic energy

4.2 Consider upward motion as positive:

$v_f^2 = v_i^2 + 2a\Delta y$   
 $0 = v_i^2 + 2(-9,8)(6)^2$   
 $v_i = 10,84 \text{ m.s}^{-1}$

Impulse =  $\Delta p$   
 $= [(0,3)(-10,84) - (0,3)(-22,13)]$   
 $= +9,89 \text{ N.s}$  i.e.  $9,89 \text{ N.s}$  upward

4.3 Take upward as positive:

$F_{\text{net}}\Delta t = \Delta p$   
 $\therefore F_{\text{net}} = \frac{\Delta p}{\Delta t} = \frac{+9,89}{0,9} = +10,99 \text{ N}$  i.e.  $10,99 \text{ N}$  ( $11 \text{ N}$ ) upward

4.4

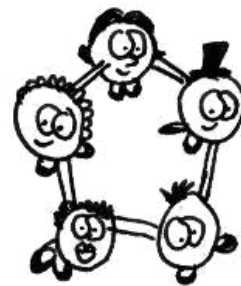
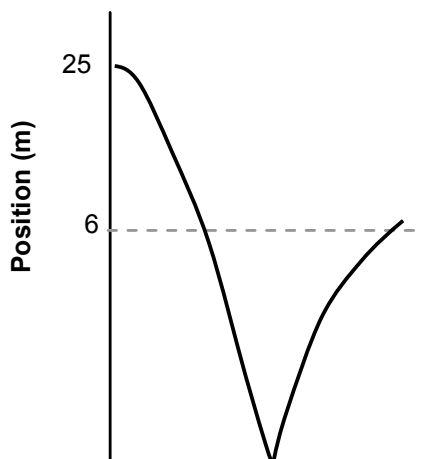

4.5 Smaller. Contact time for softer ball is longer than for rigid ball. According to  $F_{\text{net}}\Delta t = \Delta p$ , the force exerted by the floor on the softer ball is smaller than on the rigid ball.

## QUESTION 5

- 5.1 In a closed system the total linear momentum before a collision or explosion will be equal to the total linear momentum after the collision or explosion.

OR

Momentum in a closed system remains conserved in both magnitude and direction.

- 5.2 False, because of inertia the body tends to carry on in its original state of motion in a straight line.

5.3  $\Delta p = m\Delta v$   
 $= m(v - u)$   
 $= 175(0 - 20)$   
 $= -3\,500 \text{ kg}\cdot\text{m}\cdot\text{s}^{-1}$   
 $= 3\,500 \text{ kg}\cdot\text{m}\cdot\text{s}^{-1}$  is the opposite direction of motion

$$\begin{aligned} m &= 75 + 100 \\ &= 175 \text{ kg} \\ v &= 0 \\ u &= 20 \text{ m}\cdot\text{s}^{-1} \end{aligned}$$

5.4  $F\Delta t = \Delta p = m\Delta v$   
 $= -3\,500$   
 $F = -\frac{3\,500}{\Delta t}$   
 $= -\frac{3\,500}{8}$   
 $= -437,5 \text{ N}$   
 $= 437,5 \text{ N}$  in the opposite direction of motion

$$\begin{aligned} \Delta p &= -3\,500 \text{ kg}\cdot\text{m}\cdot\text{s}^{-1} \\ \Delta t &= 8 \text{ sec} \end{aligned}$$

5.5 work done = change in  $E_k$   
 $W = E_{k(\text{end})} - E_{k(\text{start})}$   
 $= \frac{1}{2}mv^2 - \frac{1}{2}mu^2$   
 $= \frac{1}{2}m(v^2 - u^2)$   
 $= \frac{1}{2} \times 175(0 - 20^2)$   
 $= -35\,000 \text{ J}$   
 $= 35 \text{ kJ}$  in the opposite direction of motion

$u$  or  $v_i$  is the initial velocity  
 $v$  or  $v_f$  is the final velocity  
 $t$  or  $\Delta t$  is the time taken  
 $s$  or  $\Delta x$  (horizontal) or  $\Delta y$  (vertical) is the displacement  
 $g$  or  $a$  is the acceleration due to gravity  
 $E_p$  or  $U$  is potential energy  
 $E_k$  or  $K$  is kinetic energy

## MODULE 3: ELECTRICITY AND MAGNETISM

### QUESTION 1

1.1  $V = \frac{W}{q}$   
 $q = \frac{W}{V}$   
 $= \frac{100}{220} = 0,45 \text{ C}$

$$\begin{aligned} V &= 220 \text{ V} \\ W &= 100 \text{ W} \end{aligned}$$

- 1.2 It is the difference in potential energy per unit charge between two points in a circuit.

$$V = \frac{W}{q} = \frac{E}{q}$$

1.3  $P = \frac{V^2}{R}$

$$100 = \frac{(220)^2}{R}$$

$$R = 484 \Omega$$

$$\begin{aligned} P &= 100 \text{ W} \\ V &= 220 \text{ V} \end{aligned}$$

1.4  $I$  = The amount of charge that flows through a certain point in a circuit per second.

$$I = \frac{q}{\Delta t}$$

1.5  $P = I^2 \cdot R$

$$100 = I^2 \cdot 484$$

$$I^2 = \frac{100}{484}$$

$$I = 0,45 \text{ A}$$

$$\begin{aligned} P &= 100 \text{ W} \\ R &= 484 \Omega \end{aligned}$$

1.6  $P(\text{light bulb}) = \frac{V^2}{R} = \frac{(110)^2}{484}$   
 $= 25 \text{ W}$

$$\begin{aligned} V &= 110 \text{ V} \\ R &= 484 \Omega \end{aligned}$$

The power will decrease. The light bulb will burn much less brightly because less energy per unit time will be transferred.

## QUESTION 2

2.1

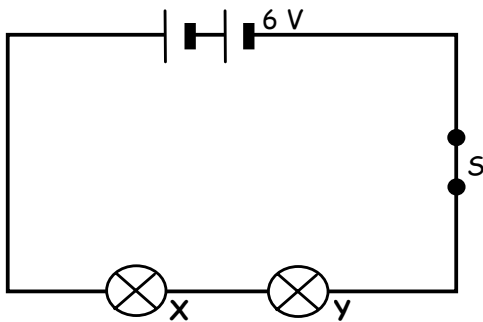

2.2 X burns brighter because its power (rate at which light energy is released) is larger than that of Y. The same magnitude current flows through both light bulbs, but the resistance of X is greater than that of Y.

$$P_X > P_Y ; R_X > R_Y [P = I^2 \cdot R]$$

2.3

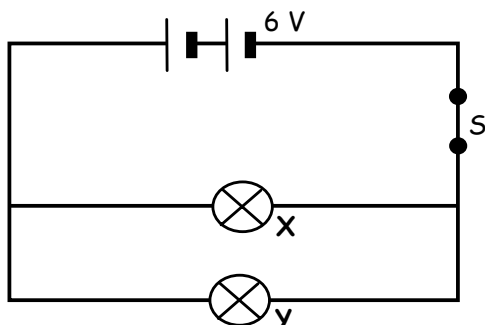

- 2.4 Because the resistance of X is greater than that of Y, the smallest current will flow through light bulb X. The same potential difference exists over both light bulbs.  
 Because:  $P_x = V.I$  (V constant; I small),  
 the power of bulb X will now be less than that of Y. X will now burn less brightly than bulb Y.

### QUESTION 3

3.1 Representation of the change in voltage with time.

3.2 Alternating current generator

$$\begin{aligned}
 3.3 \quad V_{rms} &= \frac{V_{max}}{\sqrt{2}} \\
 &= \frac{330 \text{ V}}{\sqrt{2}} \\
 &= 233,35 \text{ V}
 \end{aligned}$$

$$\begin{aligned}
 P_{ave} &= V_{rms} \times I_{rms} \\
 &= 233,33 \text{ V} \times 15 \text{ A} \\
 &= 3\,500,25 \text{ W}
 \end{aligned}$$

$$\begin{aligned}
 3.4 \quad I_{rms} &= \frac{I_{max}}{\sqrt{2}} \\
 I_{max} &= I_{rms} \times \sqrt{2} \\
 &= 15 \text{ A} \times \sqrt{2} \\
 &= 21,21 \text{ A}
 \end{aligned}$$



### QUESTION 4

$$\begin{aligned}
 4.1 \quad C &= \frac{\epsilon_0 A}{d} \\
 &= \frac{(8,85 \times 10^{-12})(40 \times 10^{-4})}{(0,01)} \\
 &= 3,54 \times 10^{-12} \text{ F}
 \end{aligned}$$

$$\begin{aligned}
 Q &= CV \\
 &= (3,54 \times 10^{-12})(12) \\
 &= 4,25 \times 10^{-11} \text{ C}
 \end{aligned}$$

4.2 Half, the area will store half the amount of charge

OR

$C \propto A$  and  $C \propto Q$ , thus  $C$  is halved.

4.3 net charge = 0 C

4.4 Discharges almost instantly to deliver a flash of light.

## QUESTION 5

$$5.1.1 \quad V_{\text{rms}} = \frac{V_{\text{max}}}{\sqrt{2}}$$

$$\therefore V_{\text{max}} = 15(\sqrt{2}) \\ = 21,21 \text{ V}$$

$$5.1.2 \quad R_{\text{total}} = 8,2 + 10,4 = 18,6 \Omega$$

$$I = \frac{V}{R} = \frac{15}{18,6} = 0,81 \text{ A}$$

$$P = I^2 R = (0,81)^2(10,4) = 6,76 \text{ W}$$



5.2 With alternating current long distance transmission may be at high voltage and low current, less loss in energy and therefore more energy available for use.

AC allows power stations to be relatively remote from users, so users are isolated from environmental effects of the stations. This remote delivery may save energy elsewhere (e.g. goods, transport and commuting).

## QUESTION 6

6.1

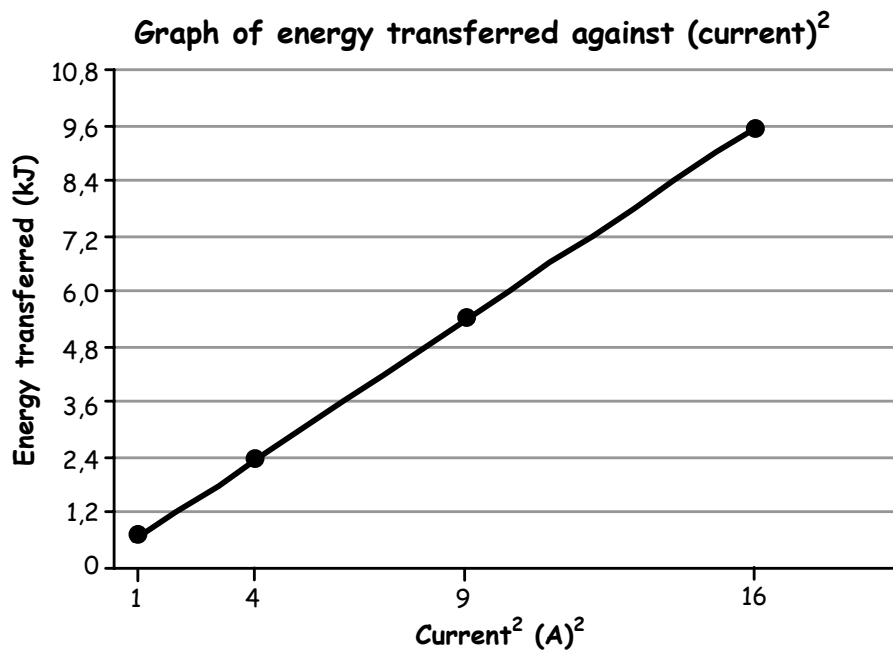

6.2 The amount of energy transferred by resistor X is directly proportional to the square of the current through the resistor.

$$6.3 \quad E = I^2 \cdot R \cdot \Delta t$$

$$600 = 1 \cdot R \cdot 300$$

$$600 = 300 \cdot R$$

$$R = \frac{600}{300}$$

$$= 2 \Omega$$

$$E = 600 \text{ J}$$

$$I^2 = 1 \text{ A}$$

$$\Delta t = 5 \text{ min}$$

$$= 5 \times 60$$

$$= 300 \text{ s}$$

[or use any other set of data from the table]

## QUESTION 7

7.1  $P = VI$

$$I = \frac{P}{V}$$

$$= \frac{3}{6}$$

$$= 0,5 \text{ A}$$

$$V = 6 \text{ V}$$

$$P = 3 \text{ W}$$

7.2

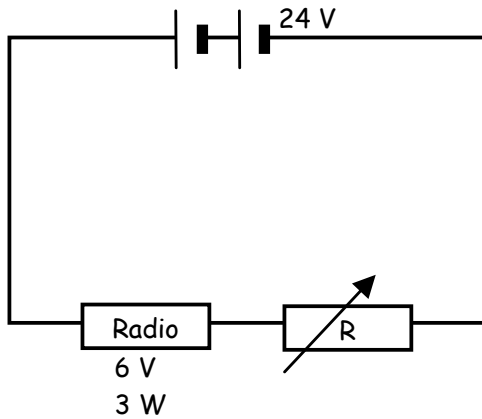

7.3  $\text{emf} = I(R + r)$

$$\text{emf} = IR + Ir$$

$$24 = 0,5.R + 0,5.2$$

$$24 = 0,5.R + 1$$

$$0,5.R = 24 - 1$$

$$R = 46 \Omega$$

$$r = 2 \Omega$$

$$I = 0,5 \text{ A}$$

$$\text{emf} = 24 \text{ V}$$

$$\therefore R \text{ of radio + resistor} = 46 \Omega$$

$$R(\text{radio}) = \frac{V}{I}$$

$$= \frac{6}{0,5} = 12 \Omega$$

$$\therefore R(\text{resistor}) = 46 - 12 = 34 \Omega$$

## QUESTION 8

$$\text{Power} = VI \therefore I = \frac{P}{V} = \frac{1\,320 \text{ W}}{220 \text{ V}} = 6 \text{ A}$$

$$\therefore Q = It$$

$$= 6 \text{ A} \times 600 \text{ s}$$

$$= 3\,600 \text{ C} \quad (3,6 \times 10^3 \text{ C})$$

## QUESTION 9

$$\text{Power} = VI \therefore I = \frac{P}{V}$$

$$\text{Heater current} = \frac{P}{V} = \frac{1\,500 \text{ W}}{200 \text{ V}} = 7,5 \text{ A}$$

$$\text{Hair dryer current} = \frac{P}{V} = \frac{1\,000 \text{ W}}{200 \text{ V}} = 5,0 \text{ A}$$

$\therefore$  Total current = 12,5 A, which is too great for the trip switch.

## MODULE 4: MATTER AND MATERIALS

### QUESTION 1

1.1 Addition

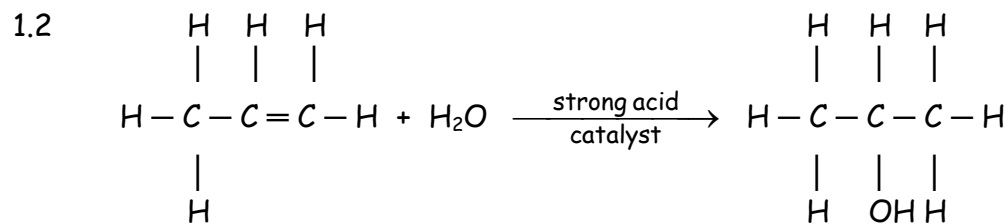

N.B. According to Markovnikov's rule, 2-propanol will be the major product and not 1-propanol.

1.3 H<sub>2</sub>O

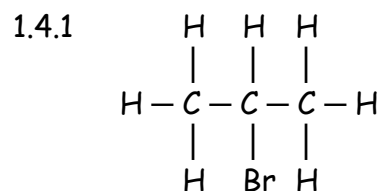

1.4.2 substitution

1.4.3 elimination

1.5.1 elimination

1.5.2 substitution

- 1.5.3
- heat (under reflux)
  - concentrated strong base/concentrated NaOH(aq)/concentrated KOH(aq)
  - ethanol as solvent/in ethanol

### QUESTION 2

2.1 cyclohexene

2.2.1 test tube/beaker, etc.

2.2.2 bromine solution/bromine water

2.2.3 Pour a few cm<sup>3</sup> of the unknown liquid into the test tube.

Add a few cm<sup>3</sup> bromine solution to the liquid in the test tube.

- 2.2.4
- The bromine will discolour immediately/fast/without additional energy.
  - An addition reaction (that is fast) took place.
  - The compound is unsaturated - only unsaturated compounds undergo addition reactions.

2.3

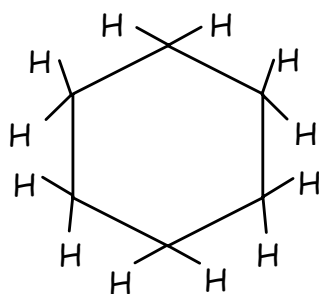

OR

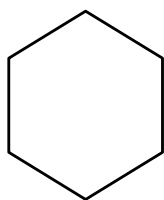

### QUESTION 3

3.1 Compounds that have the same molecular formula but different structural formulae.

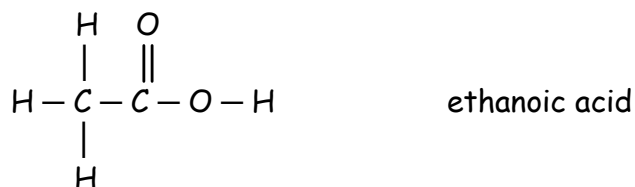
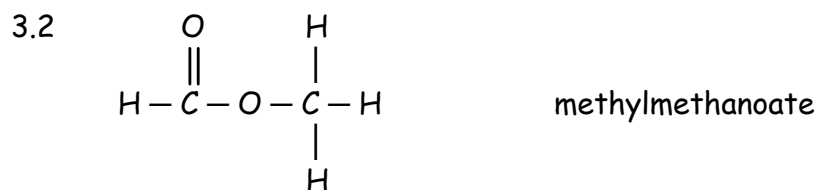

3.3.1 Ethanoic acid

- The hydrogen bonds/intermolecular forces between ethanoic acid molecules are stronger than the Van der Waals forces/intermolecular forces between the ester molecules.
- More energy needed to break bonds between the ethanoic acid molecules.

3.3.2 Methyl-methanoate

- The Van der Waals forces/intermolecular forces between the ester molecules are weaker than the hydrogen bonds/intermolecular forces between ethanoic acid molecules.
- Less energy needed to break bonds between the ester molecules.

3.4 Decrease

Van der Waals forces increase with molecular size.

### QUESTION 4

4.1 Unsaturated. Not all C - C bonds are single bonds.

OR

Contains C - C double bonds

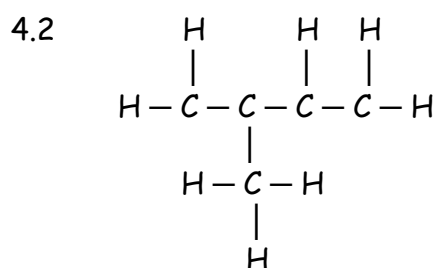

- 4.3
- Destruction of indigenous forests (leading to global warming)
  - Rubber is not biodegradable - disposal impacts negatively on environment
  - Burning of rubber releases toxic gases

- 4.4
- Job creation
  - Tyres for cars/gloves for medical industry/raincoats, etc.
  - Protective devices - insulation

### QUESTION 5

5.1 3 - elimination/dehydration

5.2 1 - hydration

2 - hydrohalogenation

5.3

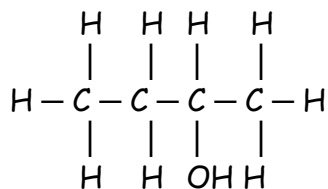

2-butanol/butan-2-ol

5.4

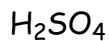

5.5

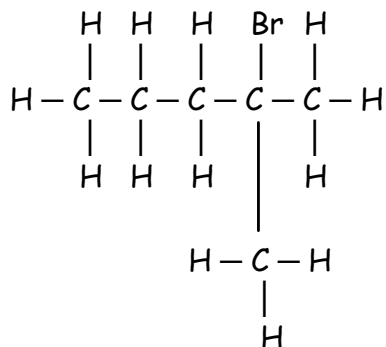

2-bromo-2-methylpentane

5.6

alkenes

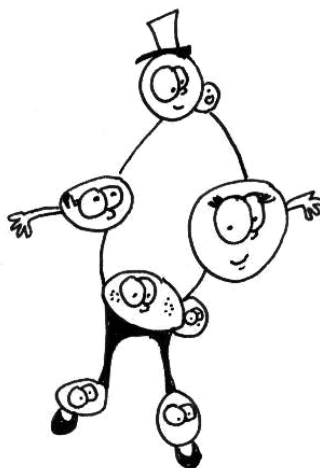
**QUESTION 6**

6.1 A ; C ; D (double bonds)

6.2 A - arenes  
 B - cycloalkanes  
 C - cycloalkenes  
 D - carboxylic acids

6.3 A - benzene  
 B - cyclohexane  
 C - cyclohexene  
 D - benzoic acid

6.4 B

6.5 D

**QUESTION 7**

7.1 A - diene  
 B - alkene  
 C - alkene  
 D - haloalkane  
 E - amine  
 F - aldehyde  
 G - alcohol  
 H - diene

7.2 A - 1,3-butdiene  
 B - 1-pentene  
 C - 2-methylpropene  
 D - bromoethane  
 E - propylamine  
 F - butanal  
 G - methanol  
 H - 1,3-pentdiene

7.3

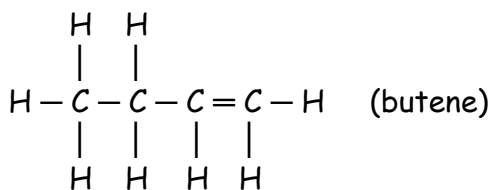

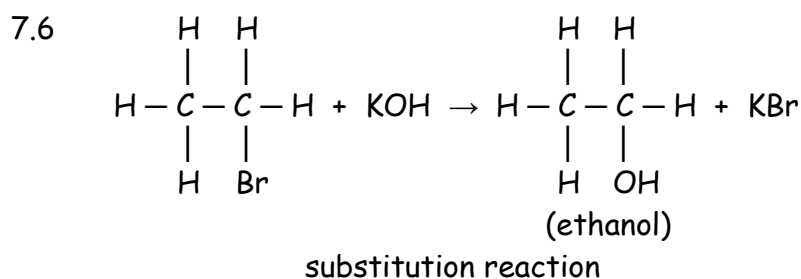
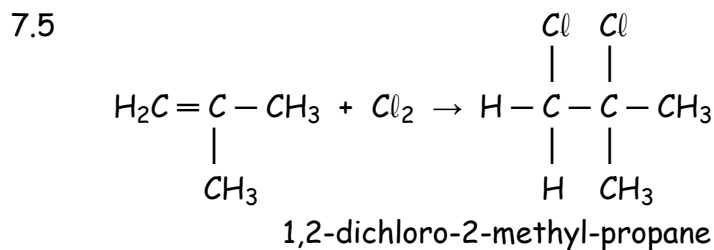
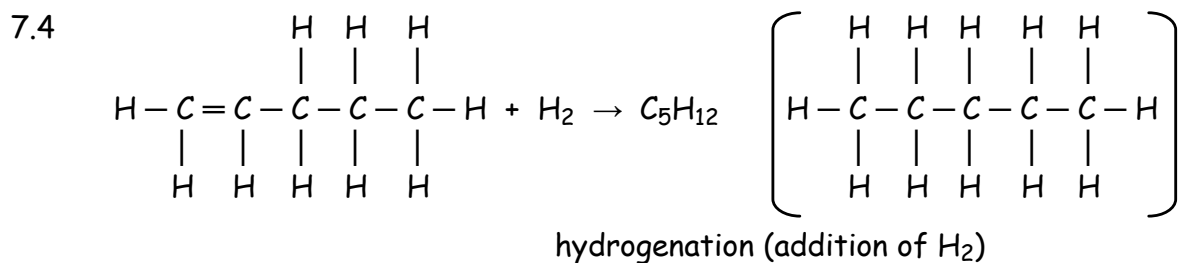

## QUESTION 8

8.1 hydrogenation (addition of H<sub>2</sub>)

8.2.1 unsaturated (has a double bond)      8.2.2 1-propene

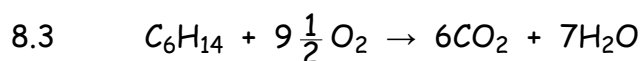
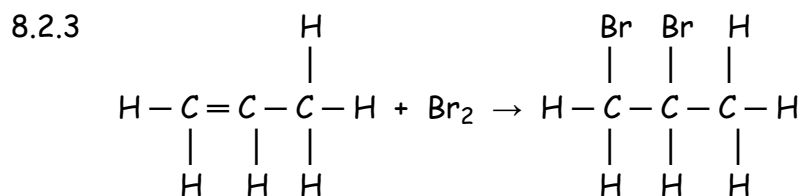

OR

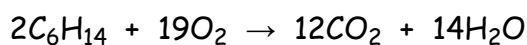

8.4.1 fermentation

8.4.2 ethyl-methanoate

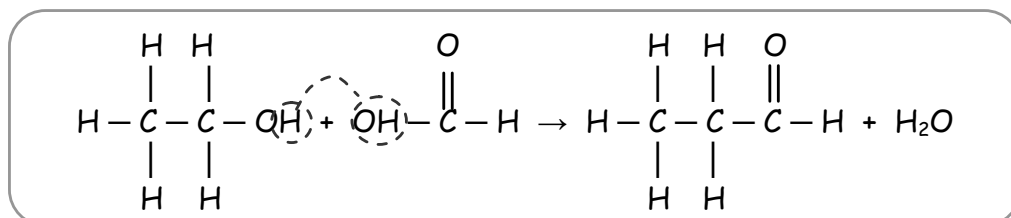

8.4.3 C acts as a catalyst to speed up the esterification process. (C = concentrated sulphuric acid that acts as a hydration agent)

## QUESTION 9

9.1.1 ethyne (acetylene)

9.1.2 alkyne

9.2  $\text{CH}_4 + 2\text{O}_2 \rightarrow \text{CO}_2 + 2\text{H}_2\text{O}$

9.3

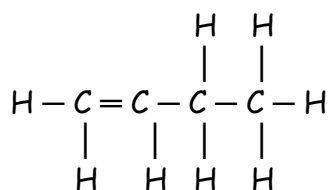

9.4.1 2,3-dibromobutane

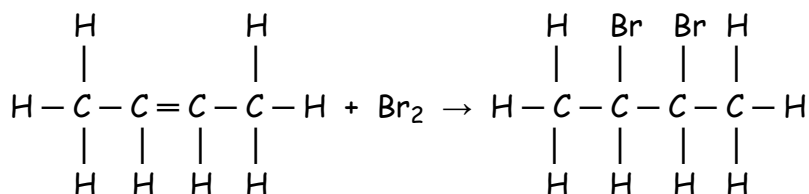

9.4.2 addition (halogenation = addition of a halogen)

## QUESTION 10

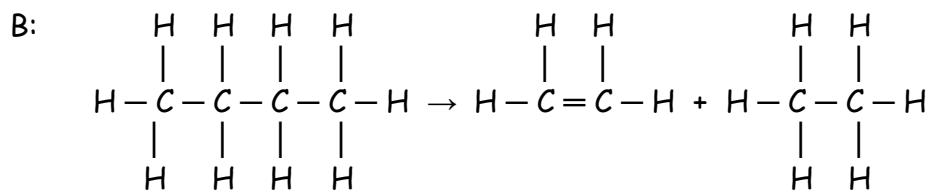
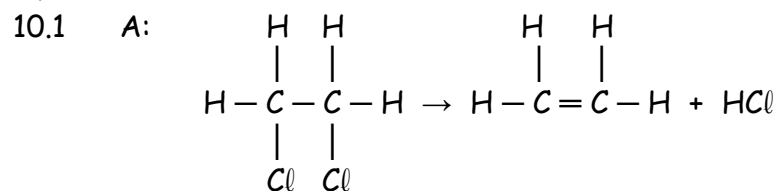

10.2 Elimination reaction (removal of a molecule from a bigger molecule)

10.3 High temperature

10.4 Cracking of an alkane (type of elimination reaction)

10.5 It is the breaking up/cracking of big alkane molecules into smaller molecules - alkanes and alkenes - by applying high pressure and/or high temperature.

10.6 Petrol industry

## QUESTION 11

11.1 platinum

11.2  $\text{C}_2\text{H}_6 \xrightarrow[800^\circ\text{C}]{\text{Pt}} \text{CH}_2=\text{CH}_2 + \text{H}_2$

OR

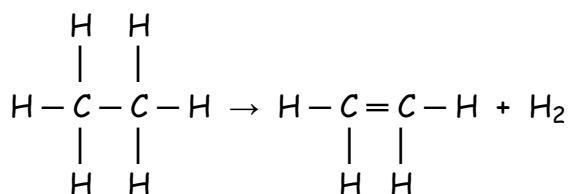

11.3 Catalytic cracking

11.4 Increasing the temperature to such a high value is a very expensive process. By adding a catalyst the reaction can be carried out at a much lower temperature.

### QUESTION 12

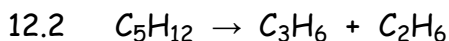
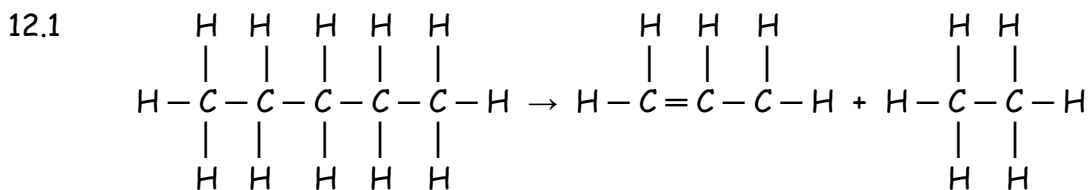

12.3 pentane  $\rightarrow$  1-propene + ethane

12.4 High temperature

12.5 Cracking



## MODULE 5: CHEMICAL CHANGE

### QUESTION 1

1.1 The addition of a catalyst

1.2 L

1.3 In test tube B no catalyst has been added. The reaction will therefore take place at a much slower rate. The amount of oxygen that is formed within a certain time will therefore also be less than in the case where a catalyst has been added.

1.4 no change

1.5 no change

### QUESTION 2

2.1.1 Decrease - forward reaction is endothermic (therefore needs energy). A decrease in temperature results in a decrease in energy. To re-establish the equilibrium the reaction that releases energy (exothermic) will be favoured, and this is the reverse reaction.

2.1.2 Increase - by increasing the volume the pressure on the system will decrease. To work against this effect the reaction that leads to the formation of more molecules (number of mols of matter) will be favoured. The forward reaction is therefore favoured.

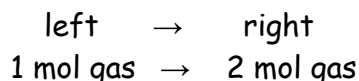

2.2 According to Le Chatelier's principle:

When the concentration of a substance in an equilibrium system is increased, that reaction that tends to decrease the concentration of the substance will be favoured. By adding a hydrochloric acid solution, the concentration of  $\text{H}_3\text{O}^+$  is increased. The reaction that decreases this concentration (uses up  $\text{H}_3\text{O}^+$ ) will now be favoured. This is the reverse reaction, therefore the solution will now be colourless.

2.3

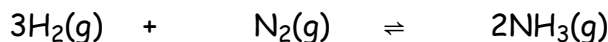

	molar ratio	3	1	2	
must be according to molar ratio	start	0,5	0,5	0,5	mol
	used/formed	3(0,1) = 0,3	0,5 - 0,4 = 0,1	2(0,1) = 0,2	mol
	equilibrium	0,5 - 0,3 = 0,2	0,5 - 0,1 = 0,4	0,5 + 0,2 = 0,7	mol

∴ At equilibrium: 0,2 mol H<sub>2</sub>

$$c = \frac{n}{V} = 0,2 \text{ mol.dm}^{-3}$$

0,4 mol N<sub>2</sub>

$$c = 0,4 \text{ mol.dm}^{-3}$$

0,7 mol NH<sub>3</sub>

$$c = 0,7 \text{ mol.dm}^{-3}$$

$$\begin{aligned} n &= cV \\ V &= 1 \text{ dm}^3 \end{aligned}$$

$$\therefore K_c = \frac{[\text{NH}_3]^2}{[\text{H}_2]^3 [\text{N}_2]} = \frac{(0,7)^2}{(0,2)^3 (0,4)} = 153,13$$

### QUESTION 3

- 3.1 When the equilibrium conditions (pressure, temperature, concentration) of an equilibrium system are changed, by increasing it or decreasing it, the reaction that tends to act against the change will be favoured.
- 3.2.1 If the volume of the container is increased, the pressure on the system will decrease. According to Le Chatelier's principle, the reaction that acts against the effect - the reaction that will increase the pressure because a greater volume of gas is formed - will be favoured. In this case it is the reverse reaction.
- 3.2.2 If the temperature is decreased, the reaction that releases energy (the exothermic reaction) will be favoured. Therefore, the temperature of the system will be increased again. In this case the forward reaction will be favoured.
- 3.2.3 By increasing the pressure on the system, the reaction that will have the opposite effect will be favoured. To decrease the pressure the reaction that forms a lower volume of gas will be favoured. In this case it is the forward reaction.
- 3.2.4 By adding more H<sub>2</sub> the concentration of H<sub>2</sub> is increased. According to the principle the reaction that will use up the H<sub>2</sub> will be favoured, and in this case it is the forward reaction.
- 3.2.5 By removing ammonia from the reaction mixture, the concentration of NH<sub>3</sub> will be lowered. The reaction producing more NH<sub>3</sub> will be favoured. In this case it is the forward reaction.
- 3.2.6 It has no influence on the equilibrium because it will increase the rate of both the forward and reverse reactions equally.
- 3.2.7 According to Le Chatelier, the opposite will now occur. The temperature must be decreased. The reaction that uses energy, the endothermic reaction, will be favoured. In this case it is the reverse reaction.

## QUESTION 4

- 4.1 X - forward  
Y - reverse

At the beginning there was no  $H_2$  and  $I_2$  in the reaction container. (We always read the reaction from left to right, and this is then also always the forward reaction.) Therefore, the reverse reaction could not have taken place. As these two gases were formed and their concentrations began to increase, the rate of the reverse reaction could then increase.

- 4.2 After 5 minutes. At this point in time both the forward and reverse reactions took place at the same rate. Equilibrium was therefore reached.
- 4.3 The pressure is increased.  
Because there are equal volumes on either side of the equation, the pressure change would not actually change the equilibrium. All that happens is that both the forward and reverse reactions will take place at a higher rate. Therefore, it increases by the same amount for both reactions.
- 4.4 - The reverse reaction will be favoured and more HI will be formed by increasing the  $H_2$  or the  $I_2$  concentration.  
- By decreasing the temperature, the reaction that releases energy will be favoured. This is the exothermic reaction. The reverse reaction now takes place faster and more HI forms.

## QUESTION 5

- 5.1 The reaction is homogenous because all of the reactants are in the same phase (gas).
- 5.2  $2SO_3(g) \rightarrow 2SO_2(g) + O_2(g)$
- 5.3 5 minutes (forward rate = reverse rate)
- 5.4 The temperature is INCREASED. Since  $\Delta H > 0$  (endothermic) the rate of the forward reaction increases more than that of the reverse reaction.
- 5.5 At a higher temperature more molecules have energy greater than the activation energy, and both reactions take place faster.
- 5.6 Decrease. By Le Chatelier's principle an increase in pressure causes a shift from 3 moles of gas on the right towards two moles of gas on the left.

## QUESTION 6

- 6.1.1  $CaCO_3(s) + 2HCl(aq) \rightarrow CaCl_2(aq) + H_2O(l) + CO_2(g)$   
Because  $CO_2$  is a gas it escapes from the beaker. (Total mass is conserved, i.e., if we kept the  $CO_2$  in the same sealed container mass would not decrease.)
- 6.1.2 The reaction stops, all the  $CaCO_3$  has reacted.
- 6.1.3 (a) Graph B Reaction takes longer to end. Lower temperature decreases reaction rate.
- (b) Graph A Mass is greater to start since more  $CaCO_3$  is present.
- (c) Graph C Reaction is faster because powdered  $CaCO_3$  has greater surface area.

6.2.1 There is very little NO gas

$$K_c = \frac{[\text{NO}]^2}{[\text{N}_2][\text{O}_2]} \quad K_c \text{ is very small} \quad \therefore [\text{NO}] \text{ is very small}$$

6.2.2

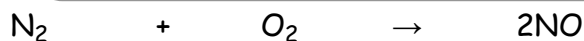

start n (mol)	7,0	2,0	0
during n <sub>used</sub> (mol)	$-\frac{0,4}{2}$	$-\frac{0,4}{2}$	
n <sub>formed</sub> (mol)			+ 0,4
equilibrium n (mol)	6,8	1,8	0,4
$c = \frac{n}{v}$ (mol.dm <sup>-3</sup> )	$\frac{6,8}{2} = 3,4$	$\frac{1,8}{2} = 0,9$	$\frac{0,4}{2} = 0,2$

$$\therefore K_c = \frac{[\text{NO}]^2}{[\text{N}_2][\text{O}_2]} = \frac{(0,2)^2}{3,4 \times 0,9} = 1,3 \times 10^{-2}$$

## MODULE 6: CHEMICAL SYSTEMS

### QUESTION 1

- 1.1 fractional distillation of (liquid) air      1.2  $\text{N}_2 + 3\text{H}_2 \rightarrow 2\text{NH}_3$
- 1.3  $2\text{SO}_2 + \text{O}_2 \rightarrow 2\text{SO}_3$                       1.4  $\text{H}_2\text{S}_2\text{O}_7$   
oleum/pyrosulphuric acid
- 1.5  $(\text{NH}_4)_2\text{SO}_4$   
ammonium sulphate

- 1.6.1 - Soil nutrients are not replenished at a fast enough rate to sustain growth.  
- Globally a bigger demand for food
- 1.6.2 - Increase in oil price  
- Increase in price of raw materials



### QUESTION 2

- 2.1 platinum/rodium catalyst
- 2.2  $4\text{NH}_3 + 5\text{O}_2 \rightarrow 4\text{NO} + 6\text{H}_2\text{O}$
- 2.3 nitric acid
- 2.4 Nitric acid is thermally unstable, it decomposes during heating (even the heat from the sun is enough) and forms a reddish brown vapour of  $\text{NO}_2$  - nitrogen dioxide. This is why concentrated nitric acid is yellow in colour. The decomposition process already starts to take place at room temperature.